

**DIVISION: 06 00 00—WOOD, PLASTICS AND COMPOSITES**  
**Section: 06 05 23—Wood, Plastic, and Composite Fastenings**

**REPORT HOLDER:**

**ALTENLOH, BRINCK & COMPANY U.S. INC.**

**EVALUATION SUBJECT:**

**SPAX® POWERLAG® SERIES STRUCTURAL WOOD FASTENERS**

**1.0 EVALUATION SCOPE**

**Compliance with the following codes:**

- 2015, 2012 and 2009 *International Building Code*® (IBC)
- 2015, 2012 and 2009 *International Residential Code*® (IRC)
- 2013 *Abu Dhabi International Building Code* (ADIBC)†

†The ADIBC is based on the 2009 IBC. 2009 IBC code sections referenced in this report are the same sections in the ADIBC.

**Properties evaluated:**

- Structural
- Corrosion resistance

**2.0 USES**

The SPAX® PowerLag® series structural wood fasteners described in this report are alternate dowel-type threaded fasteners used for wood-to-wood connections.

The SPAX® PowerLag® series structural wood fasteners having the proprietary HCR™ or HCRX™ coatings may be used where fasteners are required to exhibit corrosion resistance when exposed to adverse environmental conditions and/or chemically treated wood and are alternates to hot dip galvanized fasteners with a coating weight in compliance with ASTM A153, Class D. Fasteners having the proprietary HCR™ or HCRX™ coating have been evaluated for use with wood chemically treated with waterborne alkaline copper quaternary, Type D (ACQ-D).

**3.0 DESCRIPTION**

**3.1 General:**

The SPAX® PowerLag® series structural wood fasteners described in this report are threaded fasteners manufactured using a standard cold-forming process and subsequently heat-treated. The fasteners are available with a variety of coatings, including proprietary coating systems designated as HCR™ and HCRX™. The SPAX® PowerLag® series structural wood fasteners are available

in four different diameters and four different head types, and have lengths ranging from 2 to 24 inches (51 to 610 mm), inclusive of the threaded portion. The four head types are as follows: (1) Hex Washer Head design; (2) T-Star Washer head design with 6-Lobe recess drive system; (3) T-Star Flat Head design with 6-Lobe recess drive system; and (4) T-Star Pancake Head design with 6-Lobe recess drive system. See Tables 1A, 1B, 1C, and 1D for the diameters, lengths and head types of the 1/4, 5/16, 3/8 and 1/2 inch series, respectively. All fasteners described in this report are manufactured with cold-rolled threads and a gimlet point.

**3.2 Fastener Material:**

The fasteners are made of hardened carbon steel grade 1022 or 10B21 wire conforming to ASTM A510, or grade 17MnB3 or 19MnB4 wire conforming to DIN 1654. Specified minimum bending yield strength, allowable tensile strength, and allowable shear strength of the fasteners are listed in Tables 1A, 1B, 1C, and 1D.

**3.3 Wood Material:**

Wood main and side members must be solid-sawn lumber or boards having an assigned specific gravity as given in Tables 2, 3, 4 and 5 of this report. Assigned specific gravity must be determined in accordance with Table 12.3.3A of the 2015 ANSI/AWC National Design Specification (NDS) for Wood Construction (Table 11.3.3A of the 2012 NDS; Table 11.3.2A of the 2005 NDS).

**4.0 DESIGN AND INSTALLATION**

**4.1 Design:**

**4.1.1 Reference Design Values:** Reference design values for direct withdrawal connections are specified in Table 2 of this report. Reference design values for lateral resistance in wood-to-wood connections loaded parallel to the grain are specified in Tables 3A, 3B, 3C and 3D; and those for connections loaded perpendicular to the grain are specified in Tables 4A, 4B, 4C and 4D. When lateral loads are applied such that the fastener bears on either the main or side member in a direction other than parallel or perpendicular to the grain, the applicable design value for the connection must be calculated in accordance with Section 12.3.4 of NDS-15 (Section 11.3.4 of NDS-12 for the 2012 IBC; Section 11.3.3 of NDS-05 for the 2009 IBC), using the applicable design values given in Tables 3 and 4 of this report. Reference design values for fastener head pull-through resistance for connections having a minimum side member thickness of 1.5 inches (38 mm) are specified in Table 5.

The reference design values given in Tables 2, 3, 4 and 5 must be multiplied by all adjustment factors applicable to dowel-type fasteners and wood screws, in accordance with

the NDS, including the wet service factor,  $C_M$ , shown in Tables 2, 3 and 4, where applicable. Reference head pull-through design values must be adjusted using the NDS adjustment factors applicable to withdrawal for wood screws.

The allowable load for a single-screw connection in which the screw is subject to tension is the least of: (a) the reference withdrawal design value given in Table 2, multiplied by the thread length and adjusted by all applicable adjustment factors; (b) the reference head pull-through design value given in Table 5, adjusted by all applicable adjustment factors; and (c) the allowable screw tension strength given in Tables 1A, 1B, 1C and 1D.

The allowable lateral load for a single-screw connection is the lesser of: (a) the reference lateral design value given in Tables 3A, 3B, 3C and 3D; Tables 4A, 4B, 4C or 4D; or as determined for loading at an intermediate angle to the grain; as applicable, adjusted by all applicable adjustment factors, and (b) the allowable screw shear strength given in Tables 1A, 1B, 1C and 1D.

When designing a connection, the structural members must be checked for load-carrying capacity in accordance with Section 11.1.2 of NDS-15 (Section 10.1.2 of NDS-12 and NDS-05 for the 2012 and 2009 IBC), and local stresses within multiple-fastener connections must be checked against Appendix E of the NDS to ensure the capacity of the connection and the fastener group.

Connections comprised of multiple screws must be designed in accordance with Sections 11.2.2 and 12.6 of NDS-15 (Sections 10.2.2 and 11.6 of the NDS -12 and NDS-05 for the 2012 and 2009 IBC).

Where the screws are subjected to combined lateral and withdrawal loads, connections shall be designed in accordance with Section 12.4.1 of NDS-15 (Section 11.4.1 of the NDS-12 and NDS-05 for the 2012 and 2009 IBC).

**4.1.2 Corrosion Resistance:** The SPAX® PowerLag® series structural wood fasteners having the proprietary HCR™ or HCRX™ coating are recognized for use in wood treated with waterborne alkaline copper quaternary, Type D (ACQ-D), to a minimum retention level of 0.40 pcf (6.4 kg/m<sup>3</sup>). These fasteners must be limited to use in the typical applications described in Table 7, subject to the limitations noted in the table.

#### 4.2 Installation:

The SPAX® PowerLag® series structural wood fasteners must be installed with a 1/2-inch (12.7 mm), low rpm/high torque electric drill (450 rpm) or impact wrench using the appropriate drive bit. Lead holes are not required for the 1/4 inch and 5/16 inch series fasteners. Lead holes having diameters of 0.175 inch (4.45 mm) and 0.200 inch (5.08 mm) are required for the 3/8 inch series and 1/2 inch series fasteners, respectively, to reduce splitting of the wood. The threaded portion of the fastener, including the tip, must be embedded within the main member using the minimum fastener penetration depths shown in Tables 3A, 3B, 3C, 3D, 4A, 4B, 4C and 4D. The bottom of the fastener head must be installed flush to the surface of the member being connected. The fastener must not be overdriven.

Minimum required end and edge distances, measured from the center of the fastener to the end or edge of the wood side and main members, are specified in Table 6. Minimum required fastener spacing, measured from the center of one fastener to the center of another, is also specified in Table 6.

## 5.0 CONDITIONS OF USE

The SPAX® PowerLag® series structural wood fasteners described in this report comply with, or are suitable alternatives to what is specified in, those codes listed in Section 1.0 of this report, subject to the following conditions:

- 5.1 The screws must be installed in accordance with the manufacturer's published installation instructions and this report. In case of a conflict between this report and the manufacturer's published installation instructions, this report governs.
- 5.2 Calculations and details demonstrating compliance with this report must be submitted to the code official. The calculations and details must be prepared by a registered design professional where required by the statutes of the jurisdiction in which the project is to be constructed.
- 5.3 When the capacity of a connection is controlled by fastener metal strength, rather than wood strength, the allowable strength of the connection is not permitted to be multiplied by the adjustment factors specified in the NDS.

## 6.0 EVIDENCE SUBMITTED

- 6.1 Data in accordance with the ICC-ES Acceptance Criteria for Alternate Dowel-type Threaded Fasteners (AC233), dated April 2015.
- 6.2 Data in accordance with the ICC-ES Acceptance Criteria for Corrosion-resistant Fasteners and Evaluation of Corrosion Effects of Wood Treatment Chemicals (AC257) dated October 2009 (editorially revised May 2015).

## 7.0 IDENTIFICATION

- 7.1 The packaging for the SPAX® series structural wood fasteners is labeled with the designation "SPAX® PowerLag®"; the fastener description, including fastener head type, diameter, length and coating; the report holder's name and address; and the ICC-ES evaluation report number (ESR-1782). Each fastener is identified by the manufacturer's identifying mark "SPAX®" and the length designation, where practical with respect to available space on the fastener head.
- 7.2 The report holder's contact information is the following:

**ALTENLOH, BRINCK & COMPANY U.S. INC.**  
**02105 WILLIAMS COUNTY ROAD 12-C**  
**BRYAN, OHIO 43506**  
**(419) 636-6715**  
[www.spax.com](http://www.spax.com) or [www.trufast.com](http://www.trufast.com)

TABLE 1A—FASTENER SPECIFICATIONS: 1/4-INCH SERIES SPAX POWERLAG® STRUCTURAL WOOD FASTENERS

FASTENER DESIGNATION DIA. X OVERALL LENGTH <sup>1</sup> (inches)	AVAILABLE HEAD STYLES	THREAD LENGTH <sup>2</sup> (inches) for head styles of:			SHANK DIAMETER (inch)	MINOR THREAD DIAMETER (inch)	OUTSIDE THREAD DIAMETER (inch)	BENDING YIELD STRENGTH <sup>3</sup> (psi)	ALLOWABLE STEEL STRENGTH	
		HEX WASHER HEAD	T-STAR WASHER HEAD	T-STAR FLAT HEAD AND T-STAR PANCAKE HEAD					TENSILE (lbf)	SHEAR (lbf)
1/4 X 2"	Hex Washer Head  T-Star Washer Head  T-Star Flat Head  T-Star Pancake Head	1.770	1.375	1.375	0.195	0.170	0.276	158,000	1,169	766
1/4 X 2-1/2"		1.375								
1/4 X 3"		2.360	1.790							
1/4 X 3-1/2"			1.960							
1/4 X 4"										
1/4 X 4-1/2"										
1/4 X 5"										
1/4 X 5-1/2"										
1/4 X 6"										
1/4 X 6-1/2"										
1/4 X 7"										
1/4 X 7-1/2"										
1/4 X 8"										
1/4 X 8-1/2"										
1/4 X 9"										
1/4 X 10"			2.375							
1/4 X 11"										
1/4 X 12"										
1/4 X 13"										
1/4 X 14"										
1/4 X 15"										
1/4 X 16"										
1/4 X 18"										
1/4 X 20"										
1/4 X 22"										
1/4 X 24"										

Additional 1/4" PowerLag® Fastener Specifications:

Head Style:	Hex Washer Head	T-Star Washer Head	T-Star Flat Head	T-Star Pancake Head
Head Diameter (inch)	n/a	n/a	0.510	n/a
Washer Diameter (inch)	0.545	0.697	n/a	0.635
Head Height (inch)	0.210	0.097	n/a	0.075
Threads Per Inch	7.25	7.25	7.25	7.25
Drive System	3/8" Hex Driver	T-30 6 Lobe Recess	T-30 6 Lobe Recess	T-30 6 Lobe Recess

For SI: 1 inch = 25.4 mm; 1 psi = 6.895 kPa; 1 lbf = 4.448 N.

<sup>1</sup>For purposes of measuring overall fastener length, flat head types are measured from top of head to bottom of tip. Washer head types are measured from underside of head to bottom of tip.

<sup>2</sup>Length of thread includes tip. See detailed illustration.

<sup>3</sup>Bending yield strength determined in accordance with ASTM F1575 using minor thread diameter when fastener is tested in a threaded location.

<sup>4</sup>Tabulated fastener dimensions are as measured on uncoated fasteners.

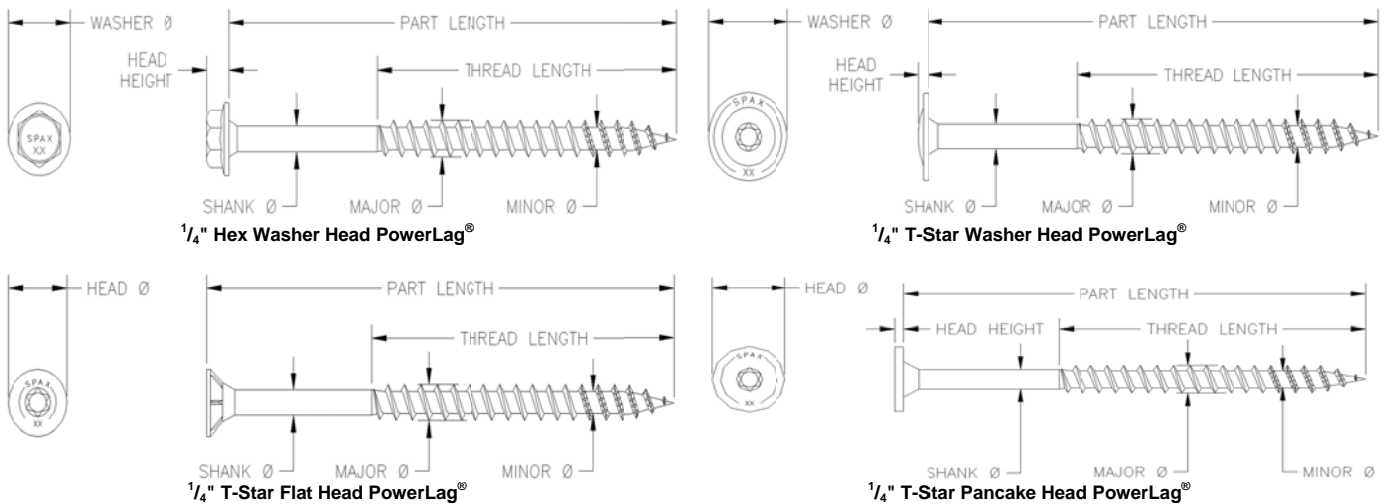

FIGURE 1A—1/4 INCH POWERLAG® SCREWS

TABLE 1B—FASTENER SPECIFICATIONS: 5/16-INCH SERIES SPAX POWERLAG® STRUCTURAL WOOD FASTENERS

FASTENER DESIGNATION DIA. X OVERALL LENGTH <sup>1</sup> (inches)	AVAILABLE HEAD STYLES	THREAD LENGTH <sup>2</sup> (inches) for head styles of:			SHANK DIAMETER (inch)	MINOR THREAD DIAMETER (inch)	OUTSIDE THREAD DIAMETER (inch)	BENDING YIELD STRENGTH <sup>3</sup> (psi)	ALLOWABLE STEEL STRENGTH		
		HEX WASHER HEAD	T-STAR WASHER HEAD	T-STAR FLAT HEAD AND T-STAR PANCAKE HEAD					TENSILE (lbf)	SHEAR (lbf)	
5/16 X 2"	Hex Washer Head	1.375	1.375	1.375	0.217	0.189	0.315	150,000	1,459	920	
5/16 X 2-1/2"											
5/16 X 3"		2.360	1.650	1.375							
5/16 X 3-1/2"		2.993	2.050								
5/16 X 4"											
5/16 X 4-1/2"											
5/16 X 5"											
5/16 X 5-1/2"											
5/16 X 6"											
5/16 X 6-1/2"											
5/16 X 7"											
5/16 X 7-1/2"		T-Star Washer Head									
5/16 X 8"											
5/16 X 8-1/2"		T-Star Flat Head									
5/16 X 9"											
5/16 X 10"		T-Star Pancake Head		2.375							
5/16 X 11"											
5/16 X 12"											
5/16 X 13"											
5/16 X 14"											
5/16 X 15"											
5/16 X 16"											
5/16 X 18"											
5/16 X 20"											
5/16 X 22"											
5/16 X 24"											

Additional 5/16" PowerLag® Fastener Specifications:

Head Style:	Hex Washer Head	T-Star Washer Head	T-Star Flat Head	T-Star Pancake Head
Head Diameter (inch)	n/a	n/a	0.570	n/a
Washer Diameter (inch)	0.591	0.776	n/a	0.610
Head Height (inch)	0.248	0.140	n/a	0.085
Threads Per Inch	6.35	6.35	6.35	6.35
Drive System	7/16" Hex Driver	T-40 6 Lobe Recess	T-40 6 Lobe Recess	T-40 6 Lobe Recess

For SI: 1 inch = 25.4 mm; 1 psi = 6.895 kPa; 1 lbf = 4.448 N.

<sup>1</sup>For purposes of measuring overall fastener length, flat head types are measured from top of head to bottom of tip. Washer head types are measured from underside of head to bottom of tip.

<sup>2</sup>Length of thread includes tip. See detailed illustration.

<sup>3</sup>Bending yield strength determined in accordance with ASTM F1575 using minor thread diameter when fastener is tested in a threaded location.

<sup>4</sup>Tabulated fastener dimensions are as measured on uncoated fasteners.

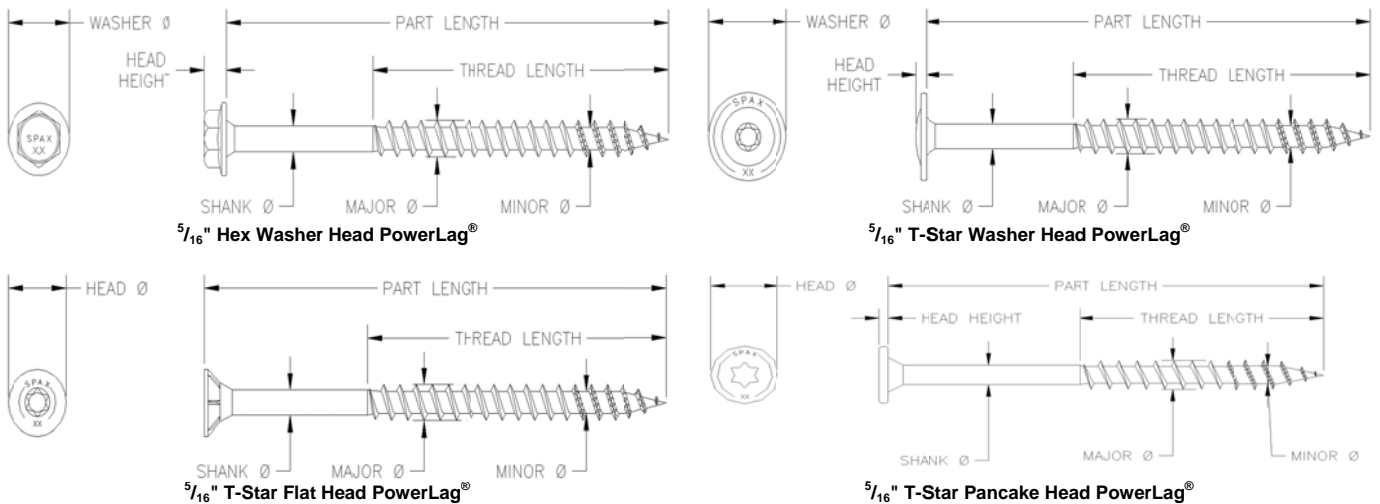

FIGURE 1B—5/16 INCH POWERLAG® SCREWS

TABLE 1C—FASTENER SPECIFICATIONS: 3/8-INCH SERIES SPAX POWERLAG® STRUCTURAL WOOD FASTENERS

FASTENER DESIGNATION DIA. X OVERALL LENGTH <sup>1</sup> (inches)	AVAILABLE HEAD STYLES	THREAD LENGTH <sup>2</sup> (inches) for head styles of:			SHANK DIAMETER (inch)	MINOR THREAD DIAMETER (inch)	OUTSIDE THREAD DIAMETER (inch)	BENDING YIELD STRENGTH <sup>3</sup> (psi)	ALLOWABLE STEEL STRENGTH	
		HEX WASHER HEAD	T-STAR WASHER HEAD	T-STAR FLAT HEAD					TENSILE (lbf)	SHEAR (lbf)
3/8 X 4"	Hex Washer Head  T-Star Washer Head  T-Star Flat Head	2.375			0.270	0.236	0.394	144,000	2,402	1,435
3/8 X 4-1/2"										
3/8 X 5"										
3/8 X 5-1/2"										
3/8 X 6"										
3/8 X 6-1/2"										
3/8 X 7"										
3/8 X 7-1/2"										
3/8 X 8"										
3/8 X 8-1/2"										
3/8 X 9"										
3/8 X 10"										
3/8 X 11"										
3/8 X 12"										
3/8 X 13"										
3/8 X 14"										
3/8 X 15"										
3/8 X 16"										
3/8 X 18"										

Additional 3/8" PowerLag® Fastener Specifications:

Head Style:	Hex Washer Head	T-Star Washer Head	T-Star Flat Head
Head Diameter (inch)	n/a	n/a	0.720
Washer Diameter (inch)	0.748	0.970	n/a
Head Height (inch)	0.307	0.173	n/a
Threads Per Inch	5.00	5.00	5.00
Drive System	1/2" Hex Driver	T-40 6 Lobe Recess	T-50 6 Lobe Recess

For SI: 1 inch = 25.4 mm; 1 psi = 6.895 kPa; 1 lbf = 4.448 N.

<sup>1</sup>For purposes of measuring overall fastener length, flat head types are measured from top of head to bottom of tip. Washer head types are measured from underside of head to bottom of tip.

<sup>2</sup>Length of thread includes tip. See detailed illustration.

<sup>3</sup>Bending yield strength determined in accordance with ASTM F1575 using minor thread diameter when fastener is tested in a threaded location.

<sup>4</sup>Tabulated fastener dimensions are as measured on uncoated fasteners.

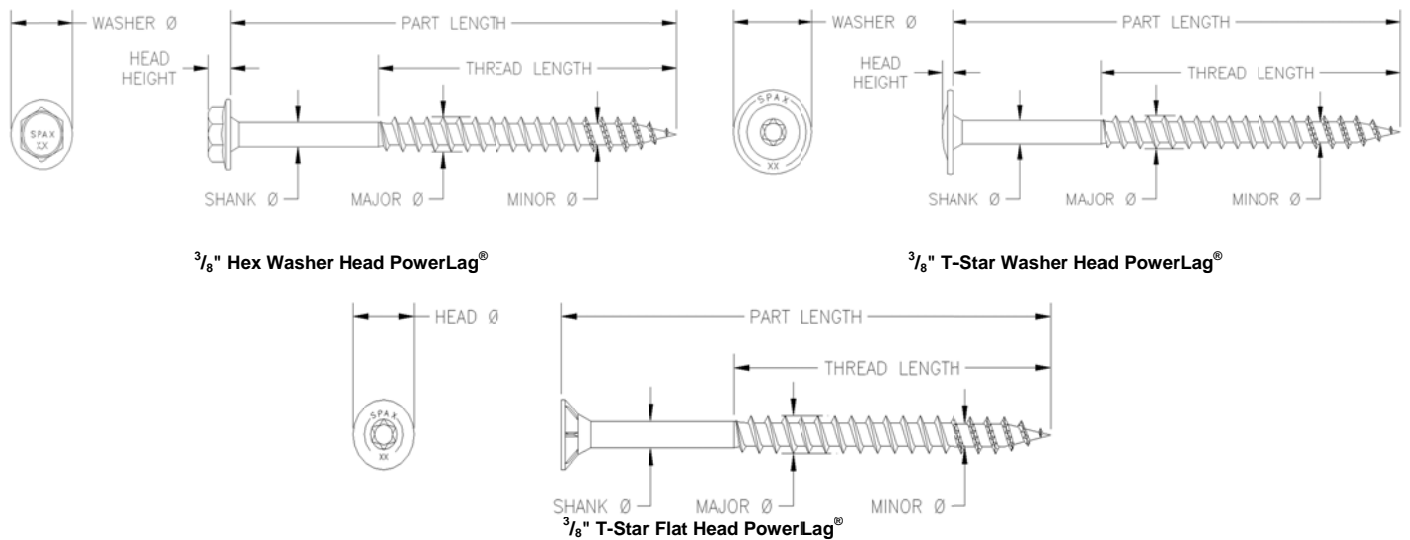

FIGURE 1C—<sup>3</sup>/<sub>8</sub>-INCH POWERLAG® SCREWS

TABLE 1D—FASTENER SPECIFICATIONS: 1/2-INCH SERIES SPAX POWERLAG® STRUCTURAL WOOD FASTENERS

FASTENER DESIGNATION DIA. X OVERALL LENGTH <sup>1</sup> (inches)	AVAILABLE HEAD STYLES	THREAD LENGTH <sup>2</sup> (inches) for head styles of:			SHANK DIAMETER (inch)	MINOR THREAD DIAMETER (inch)	OUTSIDE THREAD DIAMETER (inch)	BENDING YIELD STRENGTH <sup>3</sup> (psi)	ALLOWABLE STEEL STRENGTH	
		HEX WASHER HEAD	T-STAR WASHER HEAD	T-STAR FLAT HEAD					TENSILE (lbf)	SHEAR (lbf)
1/2 X 4"	Hex Washer Head  T-Star Flat Head	3.150	0.335	0.295	0.480	166,000	3,404	2,394		
1/2 X 4-1/2"										
1/2 X 5"										
1/2 X 5-1/2"										
1/2 X 6"										
1/2 X 6-1/2"										
1/2 X 7"										
1/2 X 7-1/2"										
1/2 X 8"										
1/2 X 8-1/2"										
1/2 X 9"										
1/2 X 10"										
1/2 X 11"										
1/2 X 12"										
<b>Additional 3/8" PowerLag® Fastener Specifications:</b>										
Head Style:	Hex Washer Head				T-Star Flat Head					
Head Diameter (inch)	n/a				0.875					
Washer Diameter (inch)	0.858				n/a					
Head Height (inch)	0.394				n/a					
Threads Per Inch	4.25				4.25					
Drive System	5/8" Hex Driver				T-50 6 Lobe Recess					

For SI: 1 inch = 25.4 mm; 1 psi = 6.895 kPa; 1 lbf = 4.448 N.

<sup>1</sup>For purposes of measuring overall fastener length, flat head types are measured from top of head to bottom of tip. Washer head types are measured from underside of head to bottom of tip.

<sup>2</sup>Length of thread includes tip. See detailed illustration.

<sup>3</sup>Bending yield strength determined in accordance with ASTM F1575 using minor thread diameter when fastener is tested in a threaded location.

<sup>4</sup>Tabulated fastener dimensions are as measured on uncoated fasteners.

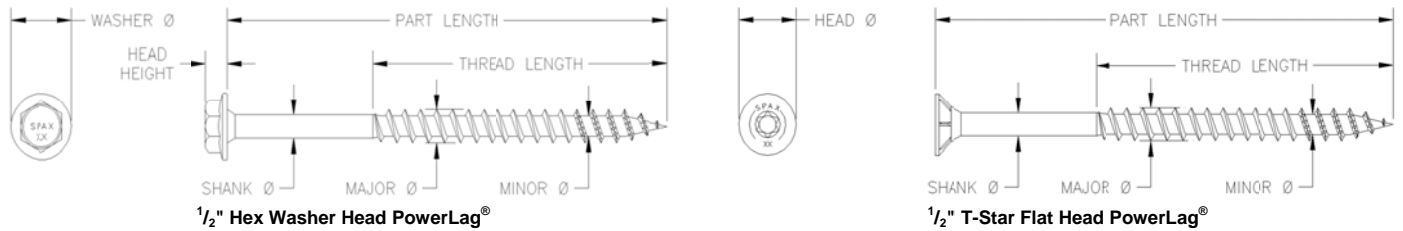

FIGURE 1D—1/2-INCH POWERLAG® SCREWS

TABLE 2—REFERENCE WITHDRAWAL DESIGN VALUES (W)<sup>1,2,3</sup>

FASTENER SERIES	HEAD STYLE	FASTENER DESIGNATION	THREAD LENGTH <sup>2</sup> , L (inches)	W (lbf./in.) FOR SPECIFIC GRAVITIES OF:						WET SERVICE FACTOR, C <sub>M</sub>	
				0.67	0.55	0.50	0.46	0.43	0.36		0.31
1/4" Spax PowerLag®	Hex Washer Head	1/4 X 2"	1.770	305	278	255	232	212	158	114	0.63
		1/4 X 2-1/2"	1.375								
		1/4 X 3"	2.360								
		1/4 X 3-1/2"									
		All Other Lengths	2.375								
	T-Star Washer Head	1/4 X 2"	1.375								
		1/4 X 2-1/2"	1.375								
		1/4 X 3"	1.790								
		1/4 X 3-1/2"	1.960								
	T-Star Flat Head and T-Star Pancake Head	1/4 X 2"	1.375								
		1/4 X 2-1/2"									
		1/4 X 3"									
		1/4 X 3-1/2"									
All Other Lengths	2.375										
5/16" Spax PowerLag®	Hex Washer Head	5/16 X 2"	1.375	388	295	259	230	210	164	133	0.67
		5/16 X 2-1/2"	1.375								
		5/16 X 3"	2.360								
		5/16 X 3-1/2"	2.993								
		5/16 X 4"									
	All Other Lengths	2.375									
	T-Star Washer Head	5/16 X 2"	1.375								
		5/16 X 2-1/2"	1.375								
		5/16 X 3"	1.650								
		5/16 X 3-1/2"	2.050								
		All Other Lengths	2.375								
	T-Star Flat Head and T-Star Pancake Head	5/16 X 2"	1.375								
		5/16 X 2-1/2"									
		5/16 X 3"									
		5/16 X 3-1/2"									
All Other Lengths		2.375									
3/8" Spax PowerLag®	Hex Washer Head and T-Star Washer Head	3/8 X 4"	2.375	469	361	317	281	254	191	146	0.64
		3/8 X 4-1/2"									
	All Other Lengths	3.105									
	T-Star Flat Head	All Lengths	2.375								
1/2" Spax PowerLag®	Hex Washer Head and T-Star Flat Head	All Lengths	3.150	506	392	345	307	279	212	165	0.62

For SI: 1 inch = 25.4 mm; 1 lbf/in = 175 N/m.

<sup>1</sup>Reference withdrawal design values must be multiplied by all applicable adjustment factors in accordance with the NDS.

<sup>2</sup>Reference withdrawal design values are to be multiplied by the length of thread penetration in the main member. Thread length includes tip.

<sup>3</sup>Reference withdrawal design values for connections in wood having specific gravities other than those given above may be interpolated from the tabulated values. Extrapolation to specific gravities greater than 0.67 or less than 0.31 is not permitted.

**TABLE 3A—REFERENCE LATERAL DESIGN VALUES FOR LOADING PARALLEL TO GRAIN ( $Z_{||}$ ) SINGLE SHEAR (TWO-MEMBER) CONNECTIONS WITH 1/4 INCH SERIES SPAX POWERLAG® STRUCTURAL WOOD FASTENERS<sup>1,3</sup>**

FASTENER DESIGNATION	SIDE MEMBER THICKNESS, $t_s$ (inches)	MINIMUM FASTENER PENETRATION <sup>2</sup> (inches)	$Z_{parallel}$ (lbf) FOR SPECIFIC GRAVITIES OF:							WET SERVICE FACTOR, $C_M$
			0.67	0.55	0.50	0.46	0.43	0.36	0.31	
1/4 X 2"	0.625	1.375	356	246	217	199	189	173	168	0.70
1/4 X 2-1/2"	1.125									
1/4 X 3"	1.625									
1/4 X 3-1/2"	2.125									
1/4 X 4"	1.625	2.375	379	313	285	263	246	207	179	
1/4 X 4-1/2"	2.125									
1/4 X 5"	2.625									
1/4 X 5-1/2"	3.125									
1/4 X 6"	3.625									
1/4 X 6-1/2"	4.125									
1/4 X 7"	4.625									
1/4 X 7-1/2"	5.125									
1/4 X 8"	5.625									
1/4 X 8-1/2"	6.125									
1/4 X 9"	6.625									
1/4 X 10"	7.625									
1/4 X 11"	8.625									
1/4 X 12"	9.625									
1/4 X 13"	10.625									
1/4 X 14"	11.625									
1/4 X 15"	12.625									
1/4 X 16"	13.625									
1/4 X 18"	15.625									
1/4 X 20"	17.625									
1/4 X 22"	19.625									
1/4 X 24"	21.625									

For SI: 1 inch = 25.4 mm; 1 lbf = 4.448 N.

<sup>1</sup>Reference lateral design values must be multiplied by all applicable adjustment factors in accordance with the NDS.

<sup>2</sup>Minimum fastener penetration depth,  $p$ , into the main member includes the length of the tip.

<sup>3</sup>Reference lateral design values for connections in wood having specific gravities other than those given above may be interpolated from the tabulated values. Extrapolation to specific gravities greater than 0.67 or less than 0.31 is not permitted.



**TABLE 3B—REFERENCE LATERAL DESIGN VALUES FOR LOADING PARALLEL TO GRAIN ( $Z_{||}$ )<sup>1,2</sup> SINGLE SHEAR (TWO-MEMBER) CONNECTIONS WITH 5/16 INCH SERIES SPAX POWERLAG® STRUCTURAL WOOD FASTENERS<sup>1,3</sup>**

FASTENER DESIGNATION	SIDE MEMBER THICKNESS, $t_s$ (inches)	MINIMUM FASTENER PENETRATION <sup>2</sup> (inches)	$Z_{parallel}$ (lbf) FOR SPECIFIC GRAVITIES OF:						WET SERVICE FACTOR, $C_M$	
			0.67	0.55	0.50	0.46	0.43	0.36		0.31
5/16 X 2"	0.625	1.375	388	270	236	215	202	180	170	0.70
5/16 X 2-1/2"	1.125									
5/16 X 3"	1.625									
5/16 X 3-1/2"	2.125									
5/16 X 4"	1.625	2.375	527	368	326	301	287	267	261	
5/16 X 4-1/2"	2.125									
5/16 X 5"	2.625									
5/16 X 5-1/2"	3.125									
5/16 X 6"	3.625									
5/16 X 6-1/2"	4.125									
5/16 X 7"	4.625									
5/16 X 7-1/2"	5.125									
5/16 X 8"	5.625									
5/16 X 8-1/2"	6.125									
5/16 X 9"	6.625									
5/16 X 10"	7.625									
5/16 X 11"	8.625									
5/16 X 12"	9.625									
5/16 X 13"	10.625									
5/16 X 14"	11.625									
5/16 X 15"	12.625									
5/16 X 16"	13.625									
5/16 X 18"	15.625									
5/16 X 20"	17.625									
5/16 X 22"	19.625									
5/16 X 24"	21.625									

For **SI**: 1 inch = 25.4 mm; 1 lbf = 4.448 N.

<sup>1</sup>Reference lateral design values must be multiplied by all applicable adjustment factors in accordance with the NDS.

<sup>2</sup>Minimum fastener penetration depth,  $p$ , into the main member includes the length of the tip.

<sup>3</sup>Reference lateral design values for connections in wood having specific gravities other than those given above may be interpolated from the tabulated values. Extrapolation to specific gravities greater than 0.67 or less than 0.31 is not permitted.

**TABLE 3C—REFERENCE LATERAL DESIGN VALUES FOR LOADING PARALLEL TO GRAIN ( $Z_{||}$ ) SINGLE SHEAR (TWO-MEMBER) CONNECTIONS WITH 3/8 INCH SERIES SPAX POWERLAG® STRUCTURAL WOOD FASTENERS<sup>1,3</sup>**

FASTENER DESIGNATION	SIDE MEMBER THICKNESS, $t_s$ (inches)	MINIMUM FASTENER PENETRATION <sup>2</sup> (inches)	$Z_{parallel}$ (lbf) FOR SPECIFIC GRAVITIES OF:						WET SERVICE FACTOR, $C_M$	
			0.67	0.55	0.50	0.46	0.43	0.36		0.31
3/8 X 4"	1.625	2.375	516	417	382	356	338	298	273	0.70
3/8 X 4-1/2"	2.125									
3/8 X 5"	2.625									
3/8 X 5-1/2"	3.125									
3/8 X 6"	3.625									
3/8 X 6-1/2"	4.125									
3/8 X 7"	4.625									
3/8 X 7-1/2"	5.125									
3/8 X 8"	5.625									
3/8 X 8-1/2"	6.125									
3/8 X 9"	6.625									
3/8 X 10"	7.625									
3/8 X 11"	8.625									
3/8 X 12"	9.625									
3/8 X 13"	10.625									
3/8 X 14"	11.625									
3/8 X 15"	12.625									
3/8 X 16"	13.625									
3/8 X 18"	15.625									

For **SI**: 1 inch = 25.4 mm; 1 lbf = 4.448 N.

<sup>1</sup>Reference lateral design values must be multiplied by all applicable adjustment factors in accordance with the NDS.

<sup>2</sup>Minimum fastener penetration depth,  $p$ , into the main member includes the length of the tip.

<sup>3</sup>Reference lateral design values for connections in wood having specific gravities other than those given above may be interpolated from the tabulated values. Extrapolation to specific gravities greater than 0.67 or less than 0.31 is not permitted.

**TABLE 3D—REFERENCE LATERAL DESIGN VALUES FOR LOADING PARALLEL TO GRAIN ( $Z_{\parallel}$ ) SINGLE SHEAR (TWO-MEMBER) CONNECTIONS WITH 1/2 INCH SERIES SPAX POWERLAG® STRUCTURAL WOOD FASTENERS<sup>1,3</sup>**

FASTENER DESIGNATION	SIDE MEMBER THICKNESS, $t_s$ (inches)	MINIMUM FASTENER PENETRATION <sup>2</sup> (inches)	$Z_{\text{parallel}}$ (lbf) FOR SPECIFIC GRAVITIES OF:							WET SERVICE FACTOR, $C_M$
			0.67	0.55	0.50	0.46	0.43	0.36	0.31	
1/2 X 4"	1.625	2.375	554	464	427	396	373	318	279	0.70
1/2 X 4-1/2"	2.125									
1/2 X 5"	2.625									
1/2 X 5-1/2"	3.125									
1/2 X 6"	3.625									
1/2 X 6-1/2"	4.125									
1/2 X 7"	4.625									
1/2 X 7-1/2"	5.125									
1/2 X 8"	5.625									
1/2 X 8-1/2"	6.125									
1/2 X 9"	6.625									
1/2 X 10"	7.625									
1/2 X 11"	8.625									
1/2 X 12"	9.625									

For SI: 1 inch = 25.4 mm; 1 lbf = 4.448 N.

<sup>1</sup>Reference lateral design values must be multiplied by all applicable adjustment factors in accordance with the NDS.

<sup>2</sup>Minimum fastener penetration depth,  $p$ , into the main member includes the length of the tip.

<sup>3</sup>Reference lateral design values for connections in wood having specific gravities other than those given above may be interpolated from the tabulated values. Extrapolation to specific gravities greater than 0.67 or less than 0.31 is not permitted.

**TABLE 4A—REFERENCE LATERAL DESIGN VALUES FOR LOADING PERPENDICULAR TO GRAIN ( $Z_{\perp}$ ) SINGLE SHEAR (TWO-MEMBER) CONNECTIONS WITH 1/4 INCH SERIES SPAX POWERLAG® STRUCTURAL WOOD FASTENERS<sup>1,3</sup>**

FASTENER DESIGNATION	SIDE MEMBER THICKNESS, $t_s$ (inches)	MINIMUM FASTENER PENETRATION <sup>2</sup> (inches)	$Z_{\text{perpendicular}}$ (lbf) FOR SPECIFIC GRAVITIES OF:							WET SERVICE FACTOR, $C_M$
			0.67	0.55	0.50	0.46	0.43	0.36	0.31	
1/4 X 2"	0.625	1.375	351	230	197	178	166	150	144	0.70
1/4 X 2-1/2"	1.125									
1/4 X 3"	1.625									
1/4 X 3-1/2"	2.125	2.375	372	298	272	252	238	209	191	
1/4 X 4"	1.625									
1/4 X 4-1/2"	2.125									
1/4 X 5"	2.625									
1/4 X 5-1/2"	3.125									
1/4 X 6"	3.625									
1/4 X 6-1/2"	4.125									
1/4 X 7"	4.625									
1/4 X 7-1/2"	5.125									
1/4 X 8"	5.625									
1/4 X 8-1/2"	6.125									
1/4 X 9"	6.625									
1/4 X 10"	7.625									
1/4 X 11"	8.625									
1/4 X 12"	9.625									
1/4 X 13"	10.625									
1/4 X 14"	11.625									
1/4 X 15"	12.625									
1/4 X 16"	13.625									
1/4 X 18"	15.625									
1/4 X 20"	17.625									
1/4 X 22"	19.625									
1/4 X 24"	21.625									

For SI: 1 inch = 25.4 mm; 1 lbf = 4.448 N.

<sup>1</sup>Reference lateral design values must be multiplied by all applicable adjustment factors in accordance with the NDS.

<sup>2</sup>Minimum fastener penetration depth,  $p$ , into the main member includes the length of the tip.

<sup>3</sup>Reference lateral design values for connections in wood having specific gravities other than those given above may be interpolated from the tabulated values. Extrapolation to specific gravities greater than 0.67 or less than 0.31 is not permitted.

**TABLE 4B—REFERENCE LATERAL DESIGN VALUES FOR LOADING PERPENDICULAR TO GRAIN ( $Z_{\perp}$ )<sup>1,2</sup> SINGLE SHEAR (TWO-MEMBER) CONNECTIONS WITH 5/16 INCH SERIES SPAX POWERLAG® STRUCTURAL WOOD FASTENERS<sup>1,3</sup>**

FASTENER DESIGNATION	SIDE MEMBER THICKNESS $S_s$ (inches)	MINIMUM FASTENER PENETRATION $N^2$ (inches)	$Z_{\perp}$ (lbf) FOR SPECIFIC GRAVITIES OF:						WET SERVICE FACTOR, $C_M$	
			0.67	0.55	0.50	0.46	0.43	0.36		0.31
5/16 X 2"	0.625	1.375	376	250	214	191	176	152	141	0.67
5/16 X 2-1/2"	1.125									
5/16 X 3"	1.625									
5/16 X 3-1/2"	2.125									
5/16 X 4"	1.625	2.375	519	340	295	269	255	237	234	
5/16 X 4-1/2"	2.125									
5/16 X 5"	2.625									
5/16 X 5-1/2"	3.125									
5/16 X 6"	3.625									
5/16 X 6-1/2"	4.125									
5/16 X 7"	4.625									
5/16 X 7-1/2"	5.125									
5/16 X 8"	5.625									
5/16 X 8-1/2"	6.125									
5/16 X 9"	6.625									
5/16 X 10"	7.625									
5/16 X 11"	8.625									
5/16 X 12"	9.625									
5/16 X 13"	10.625									
5/16 X 14"	11.625									
5/16 X 15"	12.625									
5/16 X 16"	13.625									
5/16 X 18"	15.625									
5/16 X 20"	17.625									
5/16 X 22"	19.625									
5/16 X 24"	21.625									

For SI: 1 inch = 25.4 mm; 1 lbf = 4.448 N.

<sup>1</sup>Reference lateral design values must be multiplied by all applicable adjustment factors in accordance with the NDS.

<sup>2</sup>Minimum fastener penetration depth,  $p$ , into the main member includes the length of the tip.

<sup>3</sup>Reference lateral design values for connections in wood having specific gravities other than those given above may be interpolated from the tabulated values. Extrapolation to specific gravities greater than 0.67 or less than 0.31 is not permitted.

**TABLE 4C—REFERENCE LATERAL DESIGN VALUES FOR LOADING PERPENDICULAR TO GRAIN ( $Z_{\perp}$ ) SINGLE SHEAR (TWO-MEMBER) CONNECTIONS WITH 3/8 INCH SERIES SPAX POWERLAG® STRUCTURAL WOOD FASTENERS<sup>1,3</sup>**

FASTENER DESIGNATION	SIDE MEMBER THICKNESS $S_s$ (inches)	MINIMUM FASTENER PENETRATION $N^2$ (inches)	$Z_{\perp}$ (lbf) FOR SPECIFIC GRAVITIES OF:						WET SERVICE FACTOR, $C_M$	
			0.67	0.55	0.50	0.46	0.43	0.36		0.31
3/8 X 4"	1.625	2.375	502	383	342	313	292	250	223	0.67
3/8 X 4-1/2"	2.125									
3/8 X 5"	2.625									
3/8 X 5-1/2"	3.125									
3/8 X 6"	3.625									
3/8 X 6-1/2"	4.125									
3/8 X 7"	4.625									
3/8 X 7-1/2"	5.125									
3/8 X 8"	5.625									
3/8 X 8-1/2"	6.125									
3/8 X 9"	6.625									
3/8 X 10"	7.625									
3/8 X 11"	8.625									
3/8 X 12"	9.625									
3/8 X 13"	10.625									
3/8 X 14"	11.625									
3/8 X 15"	12.625									
3/8 X 16"	13.625									
3/8 X 18"	15.625									

For SI: 1 inch = 25.4 mm; 1 lbf = 4.448 N.

<sup>1</sup>Reference lateral design values must be multiplied by all applicable adjustment factors in accordance with the NDS.

<sup>2</sup>Minimum fastener penetration depth,  $p$ , into the main member includes the length of the tip.

<sup>3</sup>Reference lateral design values for connections in wood having specific gravities other than those given above may be interpolated from the tabulated values. Extrapolation to specific gravities greater than 0.67 or less than 0.31 is not permitted.

**TABLE 4—REFERENCE LATERAL DESIGN VALUES FOR LOADING PERPENDICULAR TO GRAIN ( $Z_{\perp}$ ) SINGLE SHEAR (TWO-MEMBER) CONNECTIONS WITH 1/2 INCH SERIES SPAX POWERLAG® STRUCTURAL WOOD FASTENERS<sup>1,3</sup>**

FASTENER DESIGNATION	SIDE MEMBER THICKNESS, $t_s$ (inches)	MINIMUM FASTENER PENETRATION <sup>2</sup> (inches)	$Z_{\perp}$ (lbf) FOR SPECIFIC GRAVITIES OF:						WET SERVICE FACTOR, $C_M$	
			0.67	0.55	0.50	0.46	0.43	0.36		0.31
1/2 X 4"	1.625	2.375	522	376	326	290	266	219	193	0.67
1/2 X 4-1/2"	2.125									
1/2 X 5"	2.625									
1/2 X 5-1/2"	3.125									
1/2 X 6"	3.625									
1/2 X 6-1/2"	4.125									
1/2 X 7"	4.625									
1/2 X 7-1/2"	5.125									
1/2 X 8"	5.625									
1/2 X 8-1/2"	6.125									
1/2 X 9"	6.625									
1/2 X 10"	7.625									
1/2 X 11"	8.625									
1/2 X 12"	9.625									

For SI: 1 inch = 25.4 mm; 1 lbf = 4.448 N.

<sup>1</sup>Reference lateral design values must be multiplied by all applicable adjustment factors in accordance with the NDS.

<sup>2</sup>Minimum fastener penetration depth,  $p$ , into the main member includes the length of the tip.

<sup>3</sup>Reference lateral design values for connections in wood having specific gravities other than those given above may be interpolated from the tabulated values. Extrapolation to specific gravities greater than 0.67 or less than 0.31 is not permitted.

**TABLE 5—REFERENCE PULL-THROUGH DESIGN VALUES (P)<sup>1,2</sup>**

FASTENER SERIES	HEAD STYLE	MINIMUM SIDE MEMBER THICKNESS (inches)	P (lbf) FOR SPECIFIC GRAVITIES OF:						WET SERVICE FACTOR, $C_M$	
			0.67	0.55	0.50	0.46	0.43	0.36		0.31
1/4" Spax PowerLag®	Hex Washer Head	1.50	743	559	483	422	376	269	192	0.63
	T-Star Washer Head		701	679	608	528	456	249	118	
	T-Star Flat Head		520	337	276	232	203	148	73	
	T-Star Pancake Head		715	636	565	494	433	268	133	
5/16" Spax PowerLag®	Hex Washer Head		967	602	495	422	375	285	234	0.67
	T-Star Washer Head		996	770	676	601	544	413	319	
	T-Star Flat Head		606	429	355	296	252	148	75	
	T-Star Pancake Head		739	649	572	496	432	257	115	
3/8" Spax PowerLag®	Hex Washer Head		1,281	787	643	546	484	364	297	0.64
	T-Star Washer Head		1,326	997	869	771	699	541	436	
	T-Star Flat Head		776	501	417	361	323	250	208	
1/2" Spax PowerLag®	Hex Washer Head		1,316	946	807	702	627	466	363	0.62
	T-Star Flat Head	955	657	561	496	453	377	341		

For SI: 1 inch = 25.4 mm; 1 lbf = 4.448 N.

<sup>1</sup>Reference pull-through design values must be multiplied by adjustment factors as applicable to reference withdrawal design values,  $W$ , in accordance with the NDS.

<sup>2</sup>Reference pull-through design values for connections in wood having specific gravities other than those given above may be interpolated from the tabulated values. Extrapolation to specific gravities greater than 0.67 or less than 0.31 is not permitted.

TABLE 6—MINIMUM EDGE DISTANCES, END DISTANCES AND FASTENER SPACING<sup>1</sup>

FASTENER SERIES	SHANK DIAMETER (inches)	MINIMUM EDGE DISTANCE Loading Parallel or Perpendicular to Grain (inches)	MINIMUM END DISTANCE (inches)			MINIMUM ON-CENTER SPACING (inches)			
			Loaded Parallel to Grain		Loaded Perp. To Grain	Between Fasteners in a Row		Between Rows	
			Bearing Toward End	Bearing Away From End		Parallel to Grain	Perp. To Grain	In-line	Staggered <sup>3</sup>
1/4" Spax PowerLag®	0.195	1 1/2	3	2	2	3	2	1	1/2
5/16" Spax PowerLag®	0.217	1 3/4	3 3/4	2 3/8	2 3/8	3 1/4	2 3/16	1 1/8	5/8
3/8" Spax PowerLag® <sup>2</sup>	0.270	2 1/4	4 1/2	2 3/4	2 3/4	1 1/2	1 1/2	See 2015 NDS Table 12.5.1D (2012 and 2005 NDS Table 11.5.1D)	
1/2" Spax PowerLag® <sup>2</sup>	0.337	2 3/4	5 1/2	3	3	1 3/4	1 3/4		

For **SI**: 1 inch = 25.4 mm.

<sup>1</sup>Edge distances, end distances and spacing of the screws must be sufficient to prevent splitting of the wood, or as required by this table, whichever is greater.

<sup>2</sup>Lead holes having diameters of 0.175 inches (4.45 mm) and 0.200 inches (5.08 mm) are required for the 375 series and 500 series fasteners, respectively, to reduce splitting of the wood.

<sup>3</sup>Staggered rows must be offset by one half of the required spacing between fasteners in a row.

TABLE 7—RECOGNIZED EXPOSURE CONDITIONS FOR SPAX POWERLAG® STRUCTURAL WOOD FASTENERS

COATING SYSTEM	EXPOSURE CONDITION	TYPICAL APPLICATIONS	RECOGNITION LIMITATIONS
HCR™, HCRX™	1	Treated wood in dry use applications	Limited to use where equilibrium moisture content of the chemically treated wood meets the dry service condition as described in the NDS.
	2	Aboveground with coastal salt exposure	Limited to clean untreated wood and materials without known corrosion effects greater than that of clean untreated wood.
	3	General construction	Limited to freshwater and chemically treated wood exposure, e.g. no saltwater exposure.
HCRX™	4	Coastal construction	No limitations on use with respect to moisture and chemically treated wood except that chemical wood treatment must have the same or lesser corrosion effects as qualification conditions.