



MULTI-PLY TECHNICAL BULLETIN



MULTI-PLY FASTENING SOLUTION WITH SPAX® POWERLAGS®

SPAX 5/16" POWERLAGS® have been evaluated for single-side fastening of sawn lumber and engineered wood beams. When installed per this technical bulletin, SPAX 5/16" POWERLAGS® can be used to confidently join and secure LVL, PSL, LSL, and Sawn Lumber multi-ply beams that can be loaded on both the head and point side of the fastener.

PRODUCT FEATURES

- Code listed per ICC ESR-1782 & DrJ TER No. 1802-03.
- Patented thread technology requires no pre-drilling, and drives faster and easier than conventional lag screws.
- T-Star Washer Head for a slim, low revealing head option
- Two Coatings types to choose from:
 - Yellow Zinc - for use in interior applications
 - HCR Coatings - for use in exterior sawn lumber beams when pressure treated or fire retardant treated (FRT) lumber is specified
- Fastener length on head provides easy identification.

INSTALLATION INSTRUCTIONS

- 1) Select the proper length fastener according to Figures 4 & 6 for the given multi-ply assembly. Ensure the fastener has a minimum of 1" penetration into the last ply (main member) of the assembly.
- 2) Install using a low rpm/high torque electric drill and T-40 driver bit. Pre-drilling is typically not required but can be used when lumber is prone to splitting. When pre-drilling, use a maximum 3/16" bit.
- 3) Drive the fastener until the head is drawn firm and flush and all plies are drawn tightly together. Do not overdrive or countersink.
- 4) Install fasteners in either 2 or 3 rows (staggered or in-line) per Tables 2 & 3. For top loaded beams, refer to Figures 2 & 3. Individual screw locations may be adjusted up to 3" to avoid hardware or lumber defects.



ALTENLOH, BRINCK & CO. U.S., INC.

ALTENLOH, BRINCK & CO. - GROUP

2105 County Rd. 12C • Bryan, OH 43506 P. 419-636-6715 E. info@spax.us



ESR-1782

TER No. 1802-03

Figure 1: SPAX 5/16" T-Star Washer Head Fastener

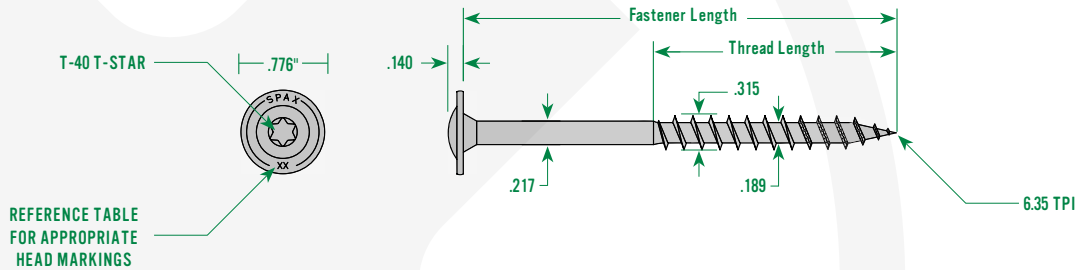

Figure 2: Minimum Spacing Requirements

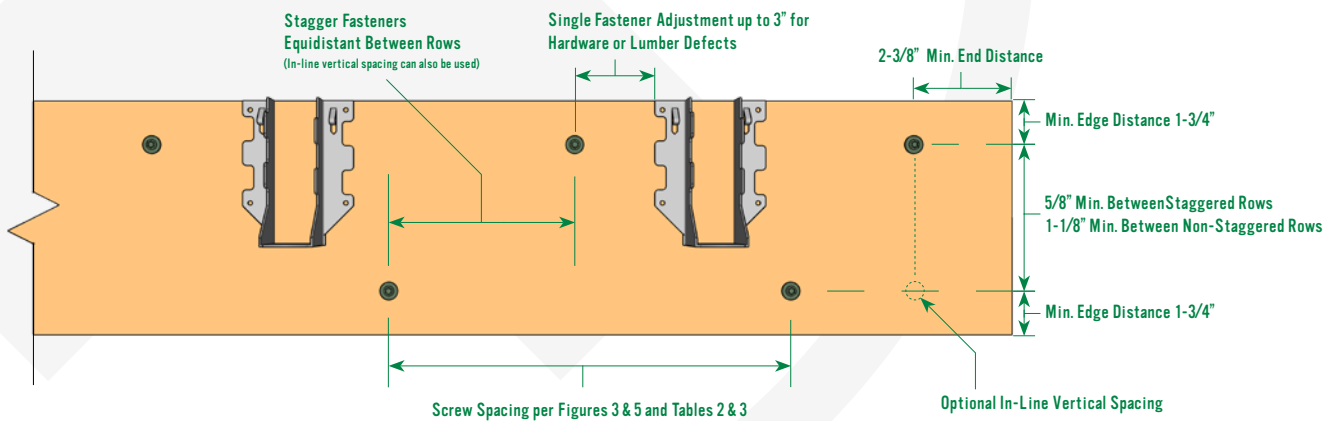

Table 1: SPAX® 5/16" Powerlag® Fastener Specifications And Strength Details

Fastener Name	Head					Fastener Length (in)	Shank Diameter (in)	Thread Length (in)	Thread Diameter (in)		Nominal Bending Yield, (psi)
	Style	Drive Type / Size	Marking	Diameter (in)	Thickness (in)				Minor	Major	
Powerlag® (5/16")	T-Star Washer	T-40	3	0.776	0.140	3	0.217	1.650	0.189	0.315	150,000
			3.5			3-1/2		2.050			
			4.5			4-1/2		2.375			
			5			5					
			6			6					
			6.7			6-3/4					

For SI: 1" = 25.4mm, 1 lbf = 4.45 N, 1 psi = 6.895 kPa.

1. Fastener length is measured from the underside of the head to the tip.
2. Thread length includes tip; see Figure 1.
3. Determine in accordance with methods specified in ASTM F1575, based on minor thread diameter using a 5% offset of the load displacement curves developed from bending tests.
4. Fastener dimensions are as measured on uncoated fasteners.

Figure 3: Top Loaded Beams

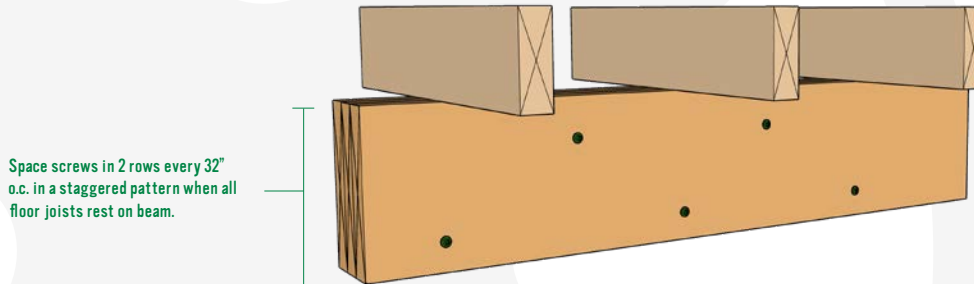

Figure 4: SPAX® 5/16" Powerlag® Fastener Assemblies for Truss and Sawn Lumber

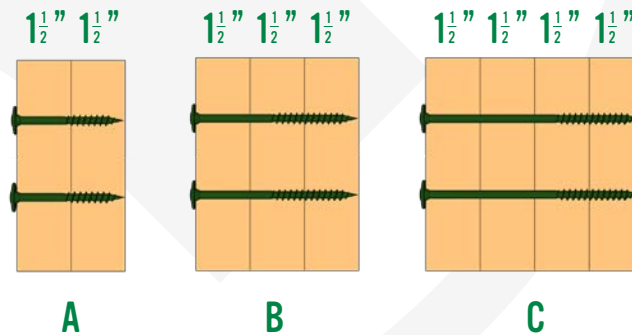

Table 2: SPAX® 5/16" Powerlag® Fastener Allowable Design Values (plf) for Multi-Ply Truss and Sawn Lumber Assemblies

Multiple Members		Nominal Fastener Length ^{1,2} (in.)	Loaded Side ³	DF-L/SP (0.50)						SPF/HF (0.42)					
				12" O.C.		16" O.C.		24" O.C.		12" O.C.		16" O.C.		24" O.C.	
Assembly	Components			2 Rows	3 Rows	2 Rows	3 Rows	2 Rows	3 Rows	2 Rows	3 Rows	2 Rows	3 Rows	2 Rows	3 Rows
A	2-ply 1-1/2"	3	Either	1710	2565	1285	1930	855	1285	1410	2115	1060	1590	705	1060
B	3-ply 1-1/2"	4.5	Either	1710	2655	1330	1995	885	1330	1530	2295	1150	1725	765	1150
C	4-ply 1-1/2"	6	Either	1575	2365	1185	1780	790	1185	1360	2040	1025	1540	680	1020

For SI: 1" = 25.4mm, 1 lbf = 4.45 N, 1 psi = 6.895 kPa.
 1. Fastener length is measured from the underside of the head to the tip.
 2. Thread length includes tip; see Figure 1.
 3. For wood species with an assigned specific gravity between 0.42 and 0.50, use the tabulated values for specific gravity of 0.42. For wood species with an assigned specific gravity greater than 0.50, use the tabulated values for specific gravity of 0.50. DF-L = Douglas Fir-Larch, SP = Southern Pine, SPF = Spruce-Pine-Fir, HF = Hem-Fir.
 4. Allowable loads are based on a load duration factor $C_D = 1.0$ and shall be multiplied by all applicable adjustment factors per the NDS.
 5. The tabulated allowable design loads may be applied to either side of the beam (head or point side of fastener). Where loads are applied to both sides of the beam simultaneously, the total load applied to the beam shall not exceed the tabulated load.
 6. All design values are also applicable to top-loaded assemblies with even loading across the width of the entire assembly. For top-loaded members, fasteners shall be installed in two (2) rows with a maximum distance of 32" o.c. between fasteners in the same row.

MULTI-PLY ENGINEERED WOOD ASSEMBLIES



Figure 5 : Top Loaded Beams

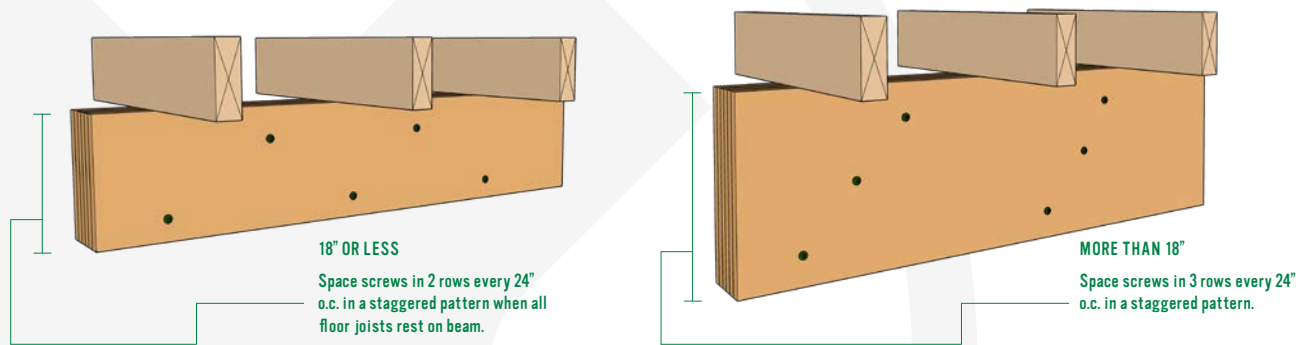

Figure 6: SPAX® 5/16" Powerlag® Fastener Assemblies for Engineered Wood

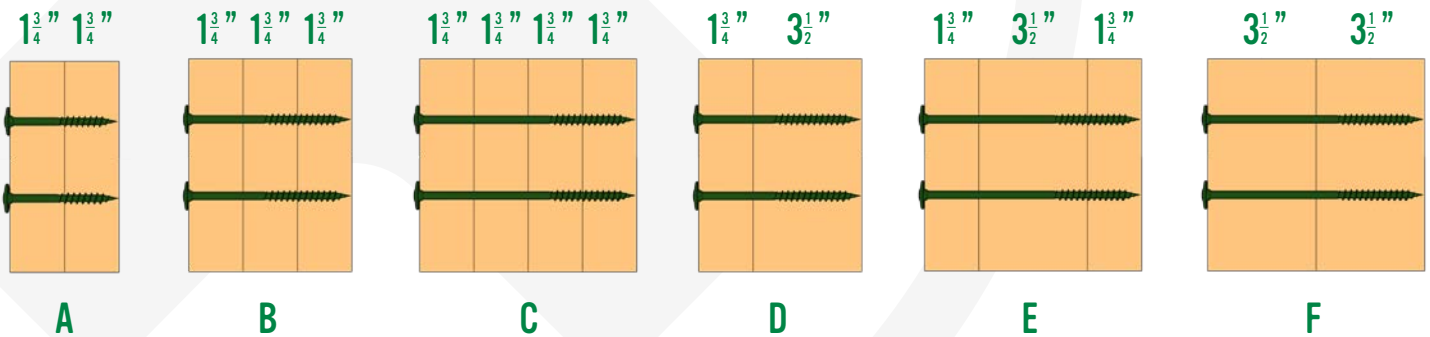

Table 3: SPAX® 5/16" Powerlag® Fastener Allowable Design Values (plf) for Multi-Ply Engineered Wood (LVL, PSL, LSL) Assemblies

Multiple Members		Nominal Fastener Length ^{1,2} (in.)	Loaded Side ⁶	12" O.C.		16" O.C.		24" O.C.	
Assembly	Components			2 Rows	3 Rows	2 Rows	3 Rows	2 Rows	3 Rows
A	2-ply 1-3/4"	3.5	Either	2175	3265	1635	2455	1090	1635
B	3-ply 1-3/4"	5	Either	1770	2655	1330	1995	885	1330
C	4-ply 1-3/4"	6.75	Either	1575	2365	1185	1780	790	1185
D	2-ply 1-3/4" & 3-1/2"	5	Either	1770	2655	1330	1995	885	1330
E	3-ply 1-3/4" & 3-1/2"	6.75	Either	1575	2365	1185	1780	790	1185
F	2-ply 3-1/2"	6.75	Either	2360	3540	1775	2665	1180	1770

For SI: 1" = 25.4mm, 1 lbf = 4.45 N, 1 psi = 6.895 kPa.

1. Fastener length is measured from the underside of the head to the tip.

2. Thread length includes tip; see Figure 1.

3. Wood members shall have an equivalent specific gravity of 0.50 or greater.

4. Allowable loads are based on a load duration factor $C_D = 1.0$ and shall be multiplied by all applicable adjustment factors per the NDS.

5. The tabulated allowable design loads may be applied to either side of the beam (head or point side of fastener). Where loads are applied to both sides of the beam simultaneously, the total load applied to the beam shall not exceed the tabulated load.

6. All design values are also applicable to top-loaded assemblies with even loading across the width of the entire assembly. For top-loaded members up to 18" deep, fasteners shall be installed in two (2) rows with a maximum distance of 24" o.c. between fasteners in the same row. Use three (3) rows for members deeper than 18".

* 2015 IRC Table R507.2, 2012 IRC Table R507.2



ALLENLOH, BRINCK & CO. U.S., INC.
ALLENLOH, BRINCK & CO. - GROUP

2105 County Rd. 12C • Bryan, OH 43506 P. 419-636-6715 E. info@spax.us



ESR-1782 TER No. 1802-03