



CERTIFICATION



Approved. Sealed. Code Compliant.

Technical Evaluation Report

TER 1711-01

SPAX® 5/16" PowerLag® Fasteners for
Use in Deck Ledger Board Applications

**Altenloh, Brinck & Company
U.S., Inc.**

Product:

**SPAX® 5/16" PowerLag®
Fasteners**

Issue Date:

March 29, 2018

Revision Date:

June 19, 2019

Subject to Renewal:

July 1, 2020

For the most recent version or a sealed copy of this Technical Evaluation Report (TER), visit drjcertification.org.



COMPANY INFORMATION:

Altenloh, Brinck & Company U.S., Inc.

02105 Williams County Rd. 12-C
Bryan, OH 43506

419-636-6715

800-443-9602

spax.us

DIVISION: 06 00 00 - WOOD, PLASTICS AND COMPOSITES

SECTION: 06 11 00 - Wood Framing

SECTION: 06 15 00 - Wood Decking

1 PRODUCT EVALUATED¹

1.1 SPAX® 5/16" PowerLag® Fasteners

2 APPLICABLE CODES AND STANDARDS^{2,3}

2.1 Codes

2.1.1 *IBC—12, 15, 18: International Building Code®*

2.1.2 *IRC—12, 15, 18: International Residential Code®*

2.2 Standards and Referenced Documents

2.2.1 *ANSI/AWC NDS: National Design Specification (NDS) for Wood Construction*

2.2.2 *ASTM A153: Standard Specification for Zinc Coating (Hot-Dip) on Iron and Steel Hardware*

2.2.3 *ASTM A510: Standard Specification for General Requirements for Wire Rods and Coarse Round Wire, Carbon Steel, and Alloy Steel*

2.2.4 *ASTM B117: Standard Practice for Operating Salt Spray (Fog) Apparatus*

2.2.5 *ASTM D1761: Standard Test Methods for Mechanical Fasteners in Wood*

2.2.6 *ASTM D2395: Standard Test Methods for Density and Specific Gravity (Relative Density) of Wood and Wood-Based Materials*

¹ Building codes require data from valid [research reports](#) be obtained from [approved sources](#). An [approved agency](#), which is an [approved source](#), is defined as "an established and recognized agency that is regularly engaged in...furnishing product certification where such agency has been approved..." Being [approved](#), defined as "acceptable to the [building official](#)," is accomplished via accreditation using ISO/IEC 17065 evaluation procedures meeting code requirements of [independence](#), [adequate equipment](#), and [experienced personnel](#). DrJ is an ISO/IEC 17065 [ANSI-Accredited Product Certification Body - Accreditation #1131](#).

Through ANSI accreditation, DrJ certification can be used to obtain product approval in any country that is an [IAF MLA Signatory](#) and covered by an [IAF MLA Evaluation](#) per the [Purpose of the MLA](#) - "certified once, accepted everywhere." Manufacturers can go to [jurisdictions](#) in any IAF MLA Signatory Country and have their products readily approved by authorities having jurisdiction using DrJ's ANSI accreditation.

For more information on any of these topics or our mission, product evaluation policies, product approval process, and engineering law, see drjcertification.org.

² Unless otherwise noted, all references in this TER are from the 2018 version of the codes and the standards referenced therein (e.g., *ASCE 7*, *NDS*, *ASTM*). This material, design, or method of construction also complies with the 2000-2015 versions of the referenced codes and the standards referenced therein. As required by [code](#), where this TER is not approved, the [building official](#) shall respond in writing stating the reasons this TER was not [approved](#). For any variations in state and local codes, see Section 8.

³ All terms defined in the applicable building codes are italicized.

- 2.2.7 *ASTM D4442: Standard Test Methods for Direct Moisture Content Measurement of Wood and Wood-Based Materials*
- 2.2.8 *ASTM G85: Standard Practice for Modified Salt Spray (Fog) Testing*

3 PERFORMANCE EVALUATION

- 3.1 PowerLag® fasteners were evaluated to determine their ability to provide code complying attachment of deck ledger boards to the building structure.
- 3.2 For conventionally framed buildings, the ledger is required to be attached to the band joist in accordance with IBC Section 1604.8.3 and IRC Section R507.8⁴ as applicable. Figure 1 is included below for reference.

CONNECTION DETAILS	JOIST SPAN						
	6' and less	6'1" to 8'	8'1" to 10'	10'1" to 12'	12'1" to 14'	14'1" to 16'	16'1" to 18'
	On-center spacing of fasteners						
1/2-inch diameter lag screw with 1/2-inch maximum sheathing ^{c, d}	30	23	18	15	13	11	10
1/2-inch diameter bolt with 1/2-inch maximum sheathing ^d	36	36	34	29	24	21	19
1/2-inch diameter bolt with 1-inch maximum sheathing ^e	36	36	29	24	21	18	16

For SI: 1 inch = 25.4 mm, 1 foot = 304.8 mm, 1 pound per square foot = 0.0479 kPa.

- a. Ledgers shall be flashed in accordance with Section R703.4 to prevent water from contacting the house band joist.
- b. Snow load shall not be assumed to act concurrently with live load.
- c. The tip of the lag screw shall fully extend beyond the inside face of the band joist.
- d. Sheathing shall be wood structural panel or solid sawn lumber.
- e. Sheathing shall be permitted to be wood structural panel, gypsum board, fiberboard, lumber or foam sheathing. Up to 1/2-inch thickness of stacked washers shall be permitted to substitute for up to 1/2 inch of allowable sheathing thickness where combined with wood structural panel or lumber sheathing.

FIGURE 1. TABLE 507.9.1.3(1)⁵: DECK LEDGER CONNECTION TO BAND JOIST^{A,B}
(DECK LIVE LOAD = 40 PSF, DECK DEAD LOAD = 10 PSF, SNOW LOAD <40 PSF)

- 3.2.1 Where a band joist is not used, as in some truss installations, an engineered design is required. See Appendix A for additional code requirements for ledger attachments.
- 3.3 Ultimate connection capacities and deflections of typical ledger board connections were match tested and evaluated in accordance with the *IRC* and *IBC*. See Appendix B for a description of testing methods.
- 3.4 Corrosion resistance in accordance with *ASTM B117* and *ASTM G85 Annex A5*.
- 3.5 Any code compliance issues not specifically addressed in this section are outside the scope of this TER.
- 3.6 Any engineering evaluation conducted for this TER was performed on the dates provided in this TER and within DrJ's professional scope of work.

4 PRODUCT DESCRIPTION AND MATERIALS

- 4.1 The product evaluated in this TER is shown in Figure 2.

⁴ 2009 IRC Section R502.2.2, 2012 IRC Section R507.1, 2015 IRC Section R507.1

⁵ 2012 IRC Table R507.2, 2015 IRC Table R507.2



FIGURE 2. POWERLAG® FASTENERS (IN)

- 4.2 PowerLag® fasteners are manufactured with carbon steel grade 1022 or 10B21 wire conforming to *ASTM A510* or grade 17MNB3 or 19MNB4 wire conforming to DIM 1654.
- 4.3 PowerLag® fasteners are manufactured using a standard cold-formed process followed by a heat-treating process. Allowable bending yield and critical dimensions are found in Figure 1 and Table 1.
 - 4.3.1 PowerLag® fastener heads are a $5/16$ " hex drive or a $5/16$ " T-star drive.
 - 4.3.2 PowerLag® fasteners have a gimlet point.
- 4.4 PowerLag® fasteners are available with proprietary coatings HCR™ and HCR-X™ that exceed the protection provided by code approved hot-dipped galvanized coatings meeting *ASTM A153* (*IBC Section 2304.10.5*⁶ and *IRC Section R317.3*).
 - 4.4.1 HCR™ coating is approved for use in ground contact and pressure treated wood (ACQ) in general construction (freshwater) applications.
 - 4.4.2 HCR-X™ coating is approved for use in ground contact and pressure treated wood (ACQ) in coastal construction (saltwater) applications.
- 4.5 HCR™ and HCR-X™ Coated Fasteners are approved for use in fire-retardant-treated lumber, provided the conditions set forth by the fire-retardant-treated lumber manufacturer are met, including appropriate strength reductions.
- 4.6 The fasteners evaluated in this TER are set forth in Table 1.

⁶ [2012 IBC Section 2304.9.5](#)

TABLE 1. POWERLAG® FASTENER SPECIFICATIONS AND STRENGTH DETAILS

Fastener Name	Head				Fastener Length ¹ (in)	Shank Diameter (in)	Thread Length ² (in)	Thread Diameter (in)		Nominal Bending Yield, f_{yb} (psi) ³
	Style	Marking	Diameter (in)	Thickness (in)				Minor	Major	
PowerLag® (5/16")	Hex	4	0.591	0.248	4	0.217	2.993	0.189	0.315	150,000
	T-Star		0.776	0.140			2.375			
	Hex	5	0.591	0.248	2.375					
	T-Star		0.776	0.140	2.375					

SI: 1" = 25.4 mm, 1 psi = 0.00689 MPa

1. Fastener length is measured from the underside of the head to the tip.
2. Thread length includes tip; see Figure 2.
3. Determined in accordance with methods specified in *ASTM F1575*, based on minor thread diameter using a 5% offset of the load displacement curves developed from bending tests.

4.7 In-plant quality control procedures, under which the PowerLag® fasteners are manufactured, are audited through an inspection process performed by an approved agency.

5 APPLICATIONS

- 5.1 PowerLag® fasteners are used for attaching the deck ledger to the band joists of a building in accordance with IBC Section 1604.8.3 and IRC Section R507.2.
- 5.2 PowerLag® fasteners are installed without lead holes as prescribed in *NDS*.
- 5.3 The IRC provides prescriptive fastener spacing for the attachment of a deck ledger to a band joist with ½"-diameter lag screws or through bolts as shown in IRC Table R507.2.
- 5.4 Table 2 provides PowerLag® fastener spacing required to provide performance at least equivalent to the lag screws found in IRC Table R507.2 in accordance with IBC Section 104.11 and Section 1604.8.3 and IRC Section R104.11 and Section R507.2 in accordance with generally accepted engineering practice.
 - 5.4.1 Table 2 provides PowerLag® fastener spacing for items found in IRC Table R507.2, as well as a wider range of materials commonly used for band joists.
 - 5.4.2 In addition, an alternate loading condition (i.e., deck live load = 60 psf, deck dead load = 10 psf) required by some jurisdictions is shown.
- 5.5 The maximum deck joist spans in ledger connection applications for PowerLag® fasteners are specified in Table 2 and Figure 3.
 - 5.5.1 When installed in accordance with the spacing requirements of Table 2, PowerLag® fasteners provide equivalent performance to IRC Table R507.2.
- 5.6 Where the application exceeds the limitations set forth herein, design shall be permitted in accordance with accepted engineering procedures, experience, and technical judgment.

TABLE 2. POWERLAG® FASTENER SPACING FOR MAXIMUM DECK JOIST SPANS

Loading Condition (Live Load, psf)	Head Type	Fastener Length (in)	2x Nominal Ledger Species	Band Joist Material	Maximum Deck Joist Spans								
					Up to 6'	Up to 8'	Up to 10'	Up to 12'	Up to 14'	Up to 16'	Up to 18'		
					Maximum On-Center Spacing of PowerLag® Fasteners								
40	T-Star	4 or 5	HF/SPF	Sawn Lumber	22	16	16	15	12	11	10		
				1" min EWP	23	17	16	15	13	11	10		
			DF/SP	Sawn Lumber	34	25	20	17	13	12	10		
				1" min EWP	23	17	16	14	12	11	9		
	Hex Head		HF/SPF	Sawn Lumber	28	21	17	12	11	9	8		
				1" min EWP	21	14	11	9	8	7	6		
			DF/SP	Sawn Lumber	30	22	18	12	10	9	8		
				1" min EWP	26	19	16	13	11	10	8		
	60		T-Star	4 or 5	HF/SPF	Sawn Lumber	16	16	12	10	9	8	7
						1" min EWP	16	16	13	11	9	8	7
DF/SP		Sawn Lumber			24	18	13	11	9	8	7		
		1" min EWP			16	15	12	10	9	7	7		
Hex Head		HF/SPF	Sawn Lumber		20	13	11	9	7	6	6		
			1" min EWP		14	10	8	7	6	5	4		
		DF/SP	Sawn Lumber		21	1	10	8	7	6	5		
			1" min EWP		18	14	11	9	8	7	6		

SI: 1" = 25.4 mm

- Based on load duration of 1.0. Spacing may be adjusted by the applicable load duration as specified in *NDS*.
- Fasteners are required to have full thread penetration into the main member. Excess fastener length extending beyond the main member is not reflected in the table above.
- Solid sawn ledgers shall be HF/SPF or DFL/SP species (specific gravity of 0.42 and 0.50 respectively), designed by others.
- Fastener spacing for 4" fasteners is based on tested loads. The design values use the lesser of a 1/8" deflection or a factor of safety equivalent to or greater than that of the code compliant lag screw application. See Figure 3.
- Fastener spacing for 5" fasteners is based on previously published reference lateral design values.
- Fasteners shall be staggered from the top to the bottom along the length of the ledger while maintaining the required edge and end distances as shown in Figure 3.
- A maximum 1/2" structural sheathing may be installed between the ledger and the band joist.
- Table values assume 10 psf dead load.
- Ledger materials assumed to be in wet service condition.
- Minimum ledger board requirements: 1 1/2" thickness and 7 1/2" depth
- Minimum band joist requirements: SPF (specific gravity of 0.42) solid-sawn lumber 1 1/2" thick and 7 1/2" depth; EWP 1.0" thick and 7 1/4" depth

6 INSTALLATION

- Installation shall comply with the manufacturer's installation instructions and this TER. In the event of a conflict between the manufacturer's installation instructions and this TER, the more restrictive shall govern.
- The 5/16" PowerLag® structural wood fastener must be installed with a 1/2" (12.7 mm), low rpm/high torque electric drill (450 rpm) or impact wrench using the appropriate driver bit. Drive the fasteners through the ledger and sheathing into the band joist until the built-in washer head is drawn firm and flush to the ledger board. Do not overdrive.
- Install PowerLag® fasteners such that the threads fully engage the band joist material and the fastener tip extends beyond the back face of the band joist material when fully seated against the installed ledger.



- 6.4 Lead holes are not required.
- 6.5 Figure 3 shows a detail of the PowerLag® fastener deck connection, including minimum edge and end distances.
- 6.6 Stagger the PowerLag® fasteners from the top to the bottom along the length of the ledger while maintaining the required edge and end distances.

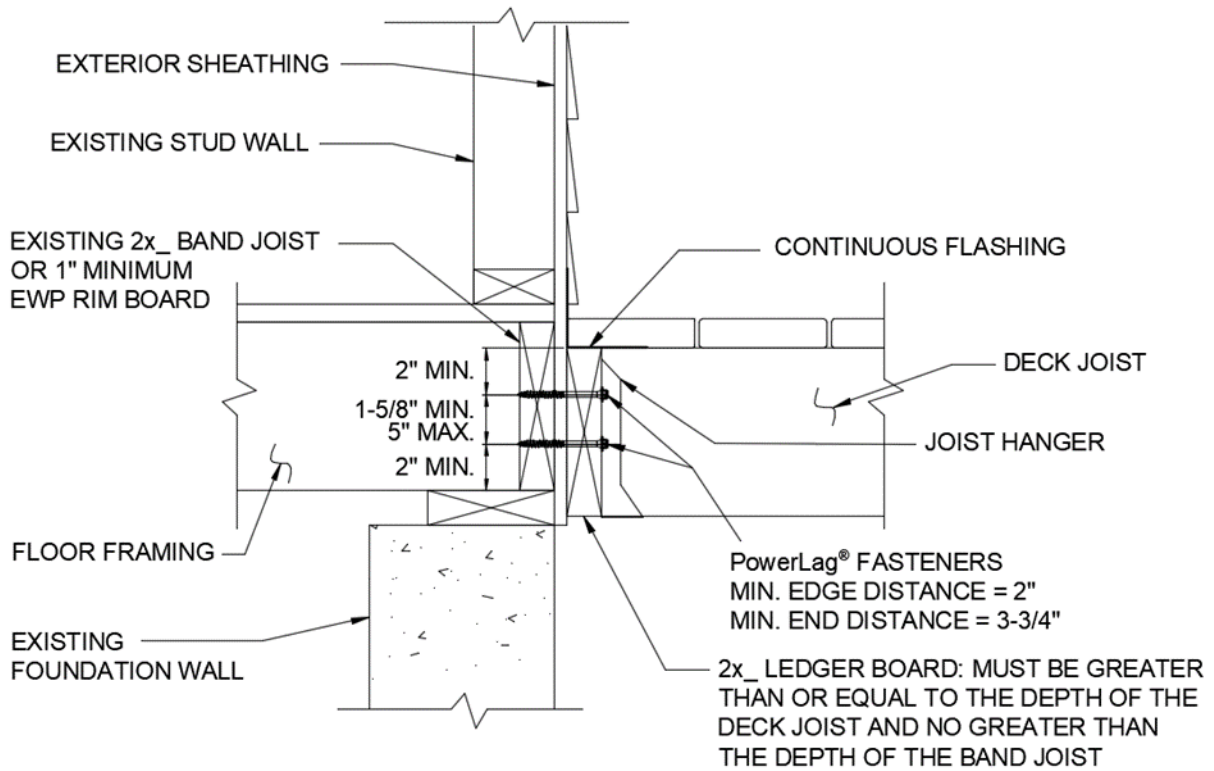

FIGURE 3. POWERLAG® FASTENER DECK CONNECTION

- 6.7 For applications outside the scope of this TER, an engineered design is required.

7 TEST ENGINEERING SUBSTANTIATING DATA

- 7.1 Testing conducted by the Structural Building Components Research Institute (SBCRI) under contract with Qualtim, Inc. for Altenloh, Brinck & Company U.S., Inc.; *SBCRI-15-0103.01* and *SBCRI-15-0103.02*.
- 7.2 Testing conducted by the University of Montana Wood Science Laboratory for Altenloh, Brink & Co.; *UMWSL Project # 2009103-1*; Final report date: July 10, 2010
- 7.3 *DCA 6, Prescriptive Residential Wood Deck Construction Guide; AF&PA; 2010*
- 7.4 Some information contained herein is the result of testing and/or data analysis by other sources which conform to *IBC Section 1703* and relevant [professional engineering law](#). DrJ relies on accurate data from these sources to perform engineering analysis. DrJ has reviewed and found the data provided by other professional sources to be credible.
- 7.5 Where appropriate, DrJ's analysis is based on design values that have been codified into law through codes and standards (e.g., *IBC*, *IRC*, *NDS®*, and *SDPWS*). This includes review of code provisions and any related test data that aids in comparative analysis or provides support for equivalency to an intended end-use application. Where the accuracy of design values provided herein is reliant upon the published properties of commodity materials (e.g., lumber, steel, and concrete), DrJ relies upon the grade mark, stamp, and/or design values provided by raw material supplier to be accurate and conforming to the mechanical properties defined in the relevant material standard.

8 FINDINGS

- 8.1 When used in accordance with this TER and the manufacturer's installation instructions, PowerLag® fasteners are a suitable alternative to the requirements of the IBC Section 1604.8.3 and IRC Section R507.2.
- 8.1.1 PowerLag® fasteners with HCR™ coating is approved for use in ground contact and pressure treated wood (ACQ) in general construction (freshwater) applications.
- 8.1.2 PowerLag® fasteners with HCR-X™ coating is approved for use in ground contact and pressure treated wood (ACQ) in coastal construction (saltwater) applications.
- 8.2 HCR™ and HCR-X™ Coated Fasteners are approved for use in fire-retardant-treated lumber, provided the conditions set forth by the fire-retardant-treated lumber manufacturer are met, including appropriate strength reductions.
- 8.3 IBC Section 104.11 (IRC Section R104.11 and IFC Section 104.9 are similar) states:
- 104.11 **Alternative materials, design and methods of construction and equipment.** The provisions of this code are not intended to prevent the installation of any material or to prohibit any design or method of construction not specifically prescribed by this code, provided that any such alternative has been *approved*. An alternative material, design or method of construction shall be *approved* where the *building official* finds that the proposed design is satisfactory and complies with the intent of the provisions of this code, and that the material, method or work offered is, for the purpose intended, not less than the equivalent of that prescribed in this code...Where the alternative material, design or method of construction is not *approved*, the *building official* shall respond in writing, stating the reasons the alternative was not *approved*.
- 8.4 This product has been evaluated in the context of the codes listed in Section 2 and is compliant with all known state and local building codes. Where there are known variations in state or local codes applicable to this evaluation, they are listed here.
- 8.4.1 No known variations

9 CONDITIONS OF USE

- 9.1 PowerLag® fasteners covered by this TER shall be installed in accordance with Section 6 of this report and the manufacturer's installation instructions.
- 9.2 PowerLag® fastener spacing shall not exceed Table 2 for code compliance and the installation conditions considered.
- 9.3 For conditions not covered in this TER, connections shall be designed in accordance with generally accepted engineering practice.
- 9.4 PowerLag® fasteners are produced under a quality control program subject to periodic inspections in accordance with IBC Section 1703.5.2.
- 9.5 Where required by the building official, also known as the authority having jurisdiction (AHJ) in which the project is to be constructed, this TER and the installation instructions shall be submitted at the time of permit application.
- 9.6 Any generally accepted engineering calculations needed to show compliance with this TER shall be submitted to the AHJ for review and approval.
- 9.7 Design loads shall be determined in accordance with the building code adopted by the jurisdiction in which the project is to be constructed and/or by the Building Designer (e.g., owner or registered design professional).
- 9.8 This product is manufactured under a third-party quality control program in accordance with IBC Section 104.4 and 110.4 and IRC Section R104.4 and R109.2.
- 9.9 The actual design, suitability, and use of this TER, for any particular building, is the responsibility of the owner or the owner's authorized agent. Therefore, the TER shall be reviewed for code compliance by the building official for acceptance.

- 9.10 The use of this TER is dependent on the manufacturer's in-plant QC, the ISO/IEC 17020 third-party quality assurance program and procedures, proper installation per the manufacturer's instructions, the *building official's* inspection, and any other code requirements that may apply to demonstrate and verify compliance with the applicable building code.

10 IDENTIFICATION

- 10.1 The product(s) listed in Section 1.1 are identified by a label on the board or packaging material bearing the manufacturer's name, product name, TER number, and other information to confirm code compliance.
- 10.2 Additional technical information can be found at spax.us.

11 REVIEW SCHEDULE

- 11.1 This TER is subject to periodic review and revision. For the most recent version of this TER, visit drjcertification.org.
- 11.2 For information on the current status of this TER, contact [DrJ Certification](#).

APPENDIX A

Code Requirements for Ledger Attachments

For guidance on designing the connection of the deck ledger to trusses where a band joist is not used, see SBCA's Tech Note, Attachment of Residential Deck Ledger to Metal Plate Connected Wood Truss Floor System.

- 1) IRC Section R507.8⁷ contains the following code requirements (IBC Section 1604.8.3 is similar):
 - a) Where supported by attachment to an exterior wall, decks shall be positively anchored to the primary structure and designed for both vertical and lateral loads.
 - i) Attachment shall not be accomplished by the use of toenails or nails subject to withdrawal.
- 2) IRC Section R507.9.1 details how vertical loads shall be transferred to band joists with ledgers:
 - a) IRC Section R507.9.1.1
 Deck ledgers shall be a minimum 2-inch by 8-inch (51 mm by 203 mm) nominal, pressure-preservative-treated Southern pine, incised pressure-preservative-treated hem-fir, or approved, naturally durable, No. 2 grade or better lumber...
 - b) IRC Section R507.9.1.2
 Band joists supporting a ledger shall be a minimum 2-inch-nominal (51 mm), spruce-pine-fir or better lumber or a minimum 1-inch by 9½-inch (25 mm x 241 mm) dimensional, Douglas fir or better, laminated veneer lumber. Band joists shall bear fully on the primary structure capable of supporting all required loads.
 - c) IRC Section R507.9.1.3⁸
 Fasteners used in deck ledger connections in accordance with Table R507.9.1.3(1) shall be hot-dipped galvanized or stainless steel and shall be installed in accordance with Table R507.9.1.3(2) and Figures R507.9.1.3(1) and R507.9.1.3(2).

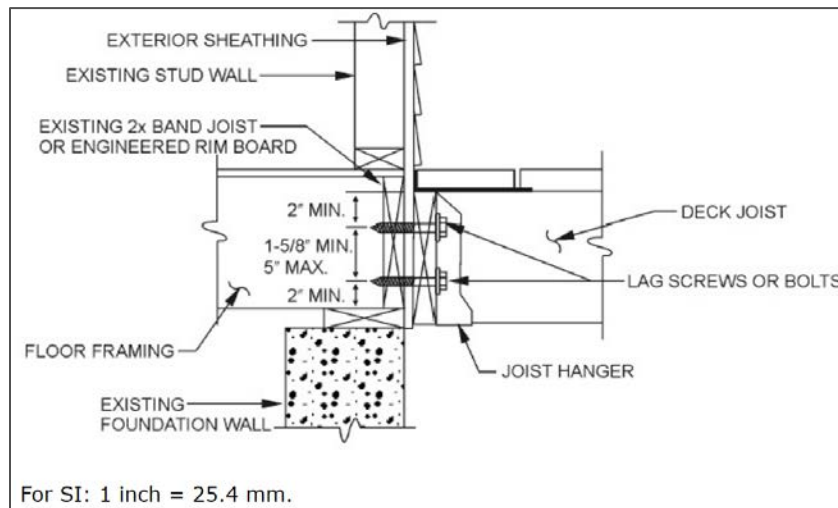

IRC FIGURE R507.9.1.3(2):

PLACEMENT OF LAG SCREWS AND BOLTS IN BAND JOISTS

- d) Tables R507.9.1.3(1) and R507.9.1.3(2)⁹ cover the placement of lag screws or bolts in deck ledgers:
 The tip of the lag screw shall fully extend beyond the inside face of the band joist

⁷ 2012 IRC Section R507.1, 2015 IRC Section R507.1

⁸ 2012 IRC Section R507.2, 2015 IRC Section R507.2

⁹ 2012 IRC Section R507.2.1, 2015 IRC Table R507.2.1, Figure R507.2.1(1) and Figure R507.2.1(2)

Lag screws or bolts shall be staggered from the top to the bottom along the horizontal run of the deck ledger in accordance with Figure R507.9.1.3(1)

The minimum distance from bottom row of lag screws or bolts to the top edge of the ledger shall be in accordance with Figure R507.9.1.3(1).

CONNECTION DETAILS	JOIST SPAN						
	6' and less	6'1" to 8'	8'1" to 10'	10'1" to 12'	12'1" to 14'	14'1" to 16'	16'1" to 18'
	On-center spacing of fasteners						
1/2-inch diameter lag screw with 1/2-inch maximum sheathing ^{c, d}	30	23	18	15	13	11	10
1/2-inch diameter bolt with 1/2-inch maximum sheathing ^d	36	36	34	29	24	21	19
1/2-inch diameter bolt with 1-inch maximum sheathing ^e	36	36	29	24	21	18	16

For SI: 1 inch = 25.4 mm, 1 foot = 304.8 mm, 1 pound per square foot = 0.0479 kPa.

- a. Ledgers shall be flashed in accordance with Section R703.4 to prevent water from contacting the house band joist.
- b. Snow load shall not be assumed to act concurrently with live load.
- c. The tip of the lag screw shall fully extend beyond the inside face of the band joist.
- d. Sheathing shall be wood structural panel or solid sawn lumber.
- e. Sheathing shall be permitted to be wood structural panel, gypsum board, fiberboard, lumber or foam sheathing. Up to 1/2-inch thickness of stacked washers shall be permitted to substitute for up to 1/2 inch of allowable sheathing thickness where combined with wood structural panel or lumber sheathing.

TABLE 507.9.1.3(1):
DECK LEDGER CONNECTION TO BAND JOIST^{a,b} (Deck live load = 40 psf, deck dead load = 10 psf, snow load ≤40 psf)

MINIMUM END AND EDGE DISTANCES AND SPACING BETWEEN ROWS				
	TOP EDGE	BOTTOM EDGE	ENDS	ROW SPACING
Ledger ^a	2 inches ^d	3/4 inch	2 inches ^b	1 5/8 inches ^b
Band Joist ^c	3/4 inch	2 inches	2 inches ^b	1 5/8 inches ^b

For SI: 1 inch = 25.4 mm.

- a. Lag screws or bolts shall be staggered from the top to the bottom along the horizontal run of the deck ledger in accordance with Figure R507.9.1.3(1).
- b. Maximum 5 inches.
- c. For engineered rim joists, the manufacturer's recommendations shall govern.
- d. The minimum distance from bottom row of lag screws or bolts to the top edge of the ledger shall be in accordance with Figure R507.9.1.3(1).

TABLE 507.9.1.3(2):
PLACEMENT OF LAG SCREWS AND BOLTS IN DECK LEDGERS AND BAND JOISTS)

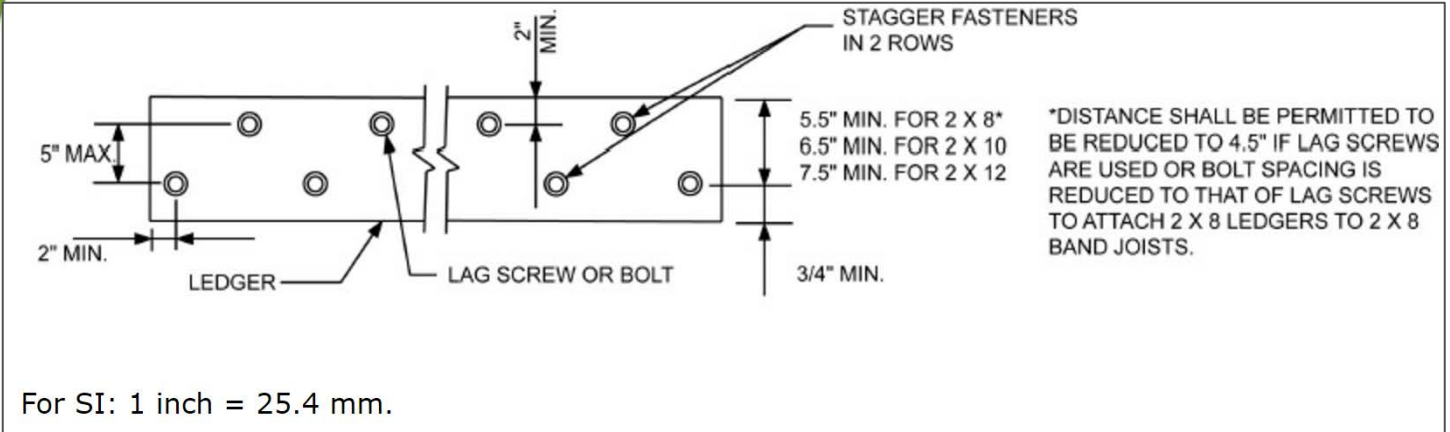

FIGURE R507.9.1.3(1):
PLACEMENT OF LAG SCREWS AND BOLTS IN LEDGERS

APPENDIX B

Testing Procedure and Methodology

1. To determine the strength and load-deflection performance of the fasteners in a ledger connection, a two-joint assembly with connection of a ledger to a band joist was created. Load was applied to the joists, which transferred load to the ledger via hangers. String potentiometers were placed along the bottom of the ledger to measure vertical deflection during the test, while a load cell attached to an actuator measured load applied. The band joist was fixed to prevent deflection and rotation during the test. To limit the variability, the comparison product was tested simultaneously with the PowerLag® fasteners with ledgers and band joists cut congruently from the same piece of lumber. Immediately after testing, a section was cut near each fastener location to determine the moisture content and oven-dry specific gravity of each piece of lumber.
2. The performance of the code defined lag screw connection was then compared to the performance of the PowerLag® fasteners in the ledger application built per the code requirements.
 - 2.1. Testing was undertaken to directly compare fastener performance using matched lumber specimen testing where the PowerLag® fastener was tested side by side with ½" diameter lag screws (see [Figure 3](#)).

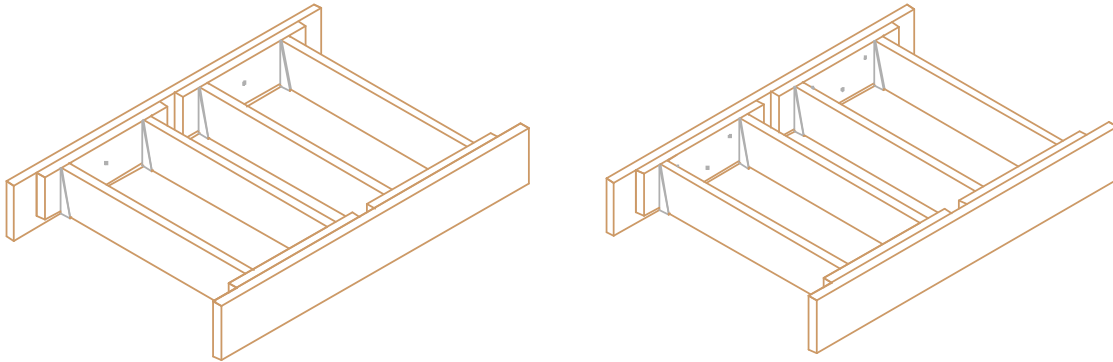

Figure 3: Single & Three-Fastener Setups

- 2.1.2. The testing and resulting analysis define comparative performance and the design parameters required for PowerLag® fasteners to be considered an equivalent alternative to the specified fasteners required by the building code in accordance with [IBC Section 104.11](#) and [IRC Section R104.11](#).